



Quick Introduction



fragmentiX Technology in a Nutshell



LAN / user side:

fragmentiX desktop client software or WebDAV-provided network drives under Windows, MacOS and Linux or acts as an S3 proxy for applications using S3 directly

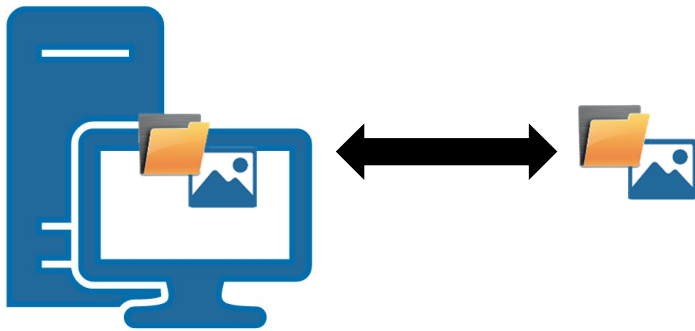

fragmentiX Secret Sharing Appliance

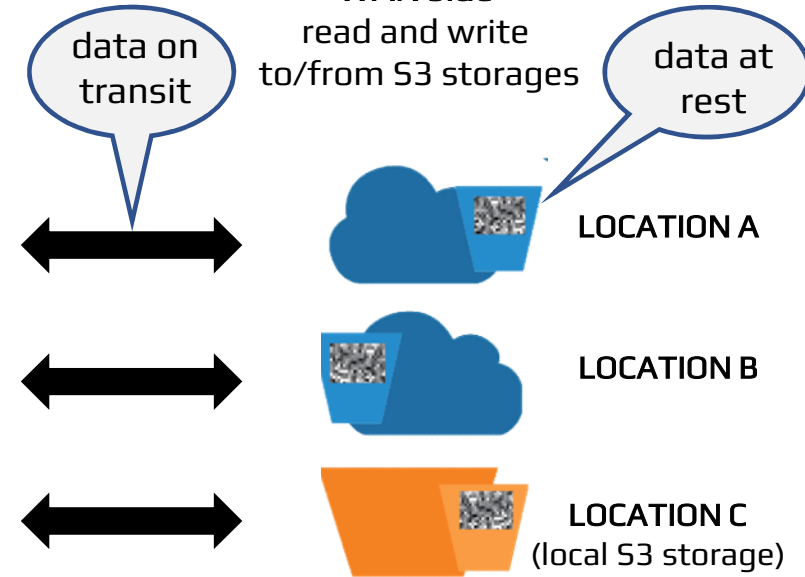
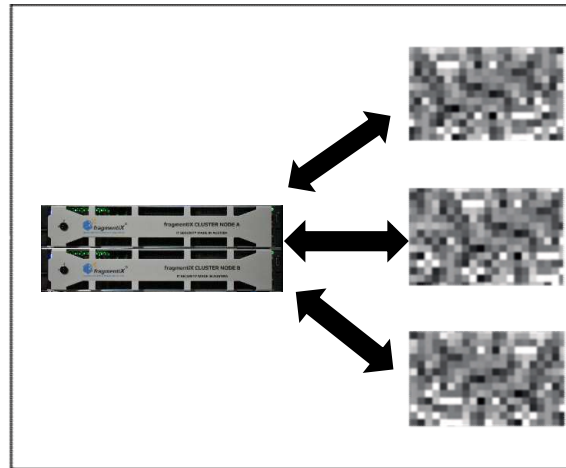

Files are saved on a fragmentiX network drive or on a virtual S3 storage

The fragmentiX appliance uses Secret Sharing algorithms to split the data into fragments

Each fragment is assigned to a separate physical storage location in a hybrid/multi cloud

Digital Sovereignty is Our Passion



We at fragmentiX are convinced that every individual human being, every company of any size as well as every state has the right to achieve Digital Sovereignty.

As an Austrian, European, and Global IT company, we want to ensure that every citizen, every company can effectively protect their knowledge and data against the effects of asymmetric hybrid warfare, data theft and industrial espionage.

Werner Strasser

CEO, fragmentiX Storage Solutions GmbH, Austria
Chairman of the Board of Directors, fragmentiX Schweiz AG, Switzerland



Selected fragmentiX Cutting-Edge Projects



Austria



... + other ministries

EU



CVSTAR



Global

TOSHIBA

Innophore



...

Cloud storage risks – Governments



As the US CLOUD Act (Clarifying Lawful Overseas Use of Data Act), country-specific governments may pass into law the right to access data stored by cloud providers having their infrastructure on their territory, or by cloud providers having their companies incorporated under their jurisdiction, even operating overseas.

US cloud act implications: regardless what US-based cloud data providers assure you of, your data is always available to thousands of US officials and agencies, without your knowledge, at anytime.

All main US-based dominant providers will always try to convince their users that their data is safe. On the other hand, it is those actors exactly that are not allowed by such law to let you know if they are requested to handover your data to any of the branches of the US government.

This is not their fault - this is just a relevant USA law that came to pass since 2018 that cloud data users must be aware of!

fragmentiX enables you to make your own choices about where on earth you decide to store your fragments, and to protect your data against governments, with industrial espionage implications.

fragmentiX Products Overview

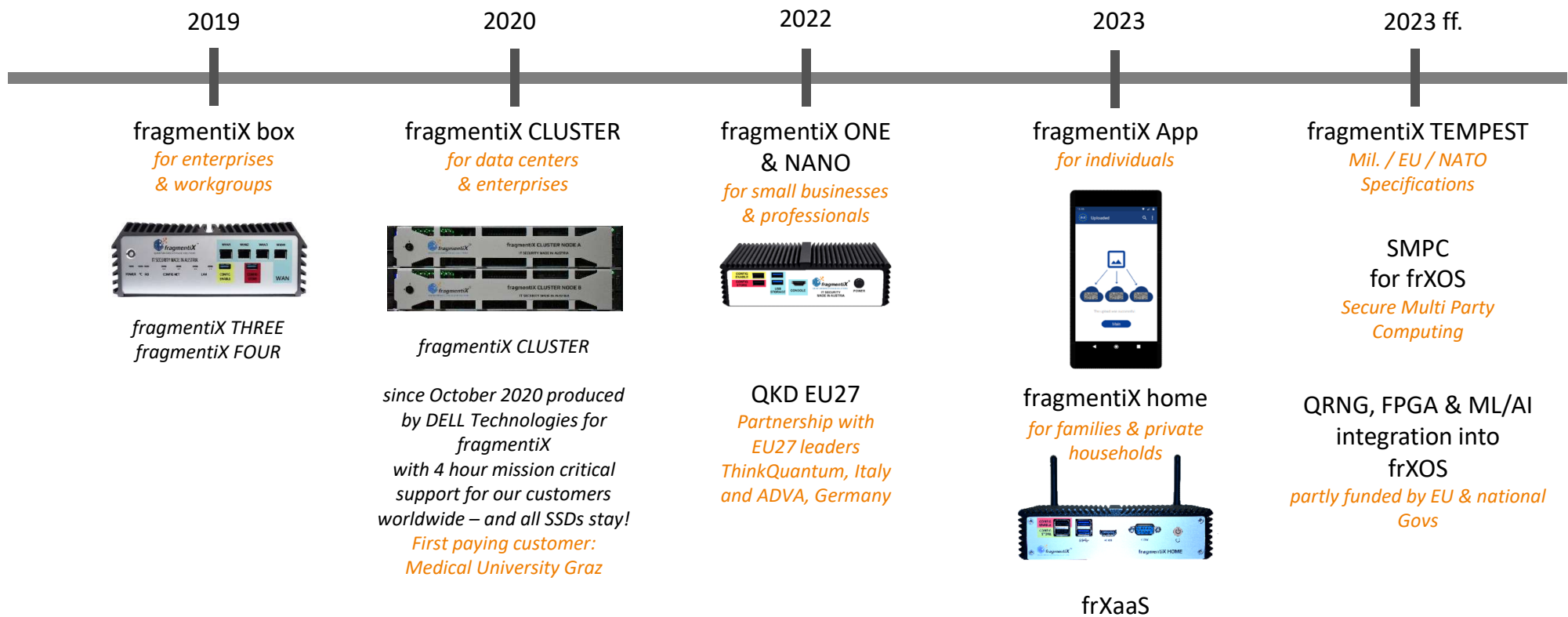

fragmentiX Advantages in a Nutshell

LOCATIONS



Each fragment is stored in its own public cloud or local S3/Azure/NFS storage LOCATION and only the owner of the files knows where these LOCATIONS are.



If one of the fragments is stolen, it is absolutely useless for the data thief or spy because fragmentiX Secret Sharing enables you to store data with ITS – Information-Theoretical Security - not even future quantum computers have a chance to break it!

We can randomly select any number of points on the straight line, depending on how many fragments are to be created. The condition is always kept that we need any two points on the straight line to reconstruct the secret byte.

As soon as only 1 point (i.e. 1 fragment) is present or known, the secret byte could take any value.

3 fragments:

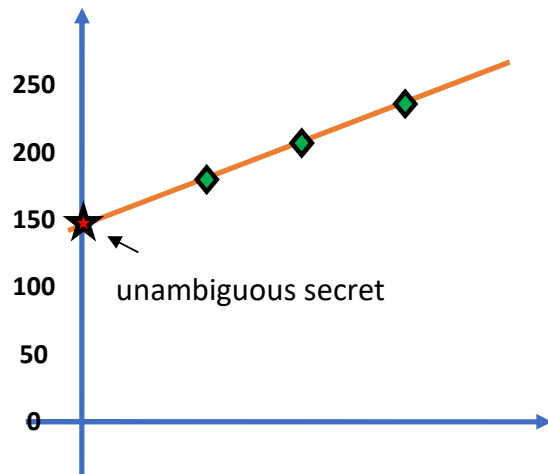

2 fragments:

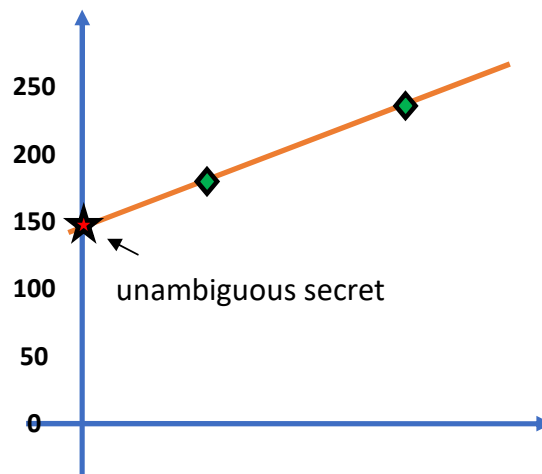

1 fragment:

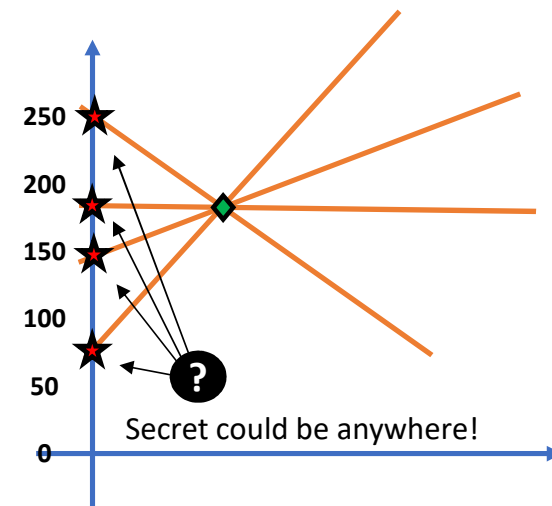

You need two points to define a line. But if e.g. 3 points are needed, then we use a parabola.

The rule is: you need 3 points to define the parabola uniquely. With 2 or less points the "secret byte" can take any value:

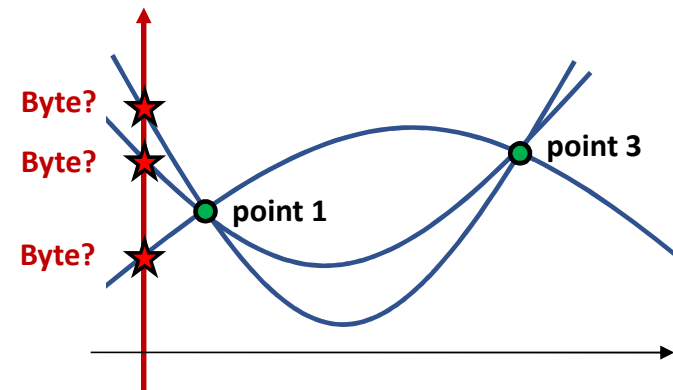
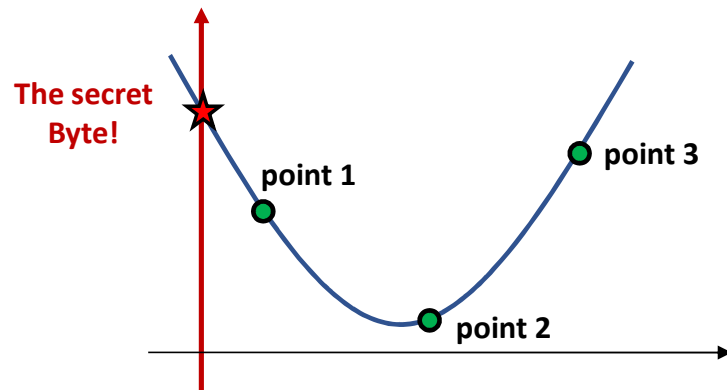

If more than 3 points (fragments) are needed, a polynomial function of higher degree must be used.

Using fragmentiX this can be extended to using up to 26 fragments.

Strategic cooperations within EU

ThinkQUANTUM

fragmentiX provides

- quantum key distribution (QKD)
- quantum random number generators (QRNG)
- satellite equipment

with a **complete European supply chain** from ThinkQuantum (ITA).

The QKD equipment can use optical fibres, free-space links, as well as satellite links.

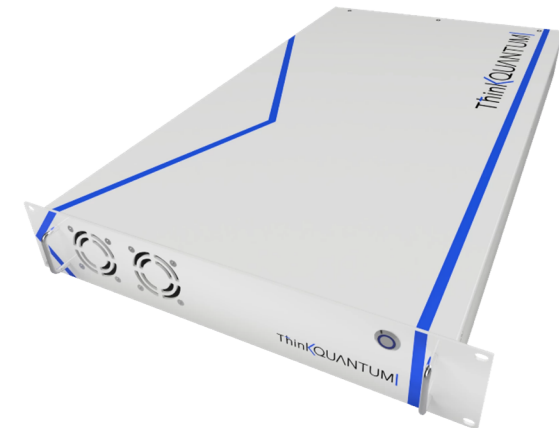
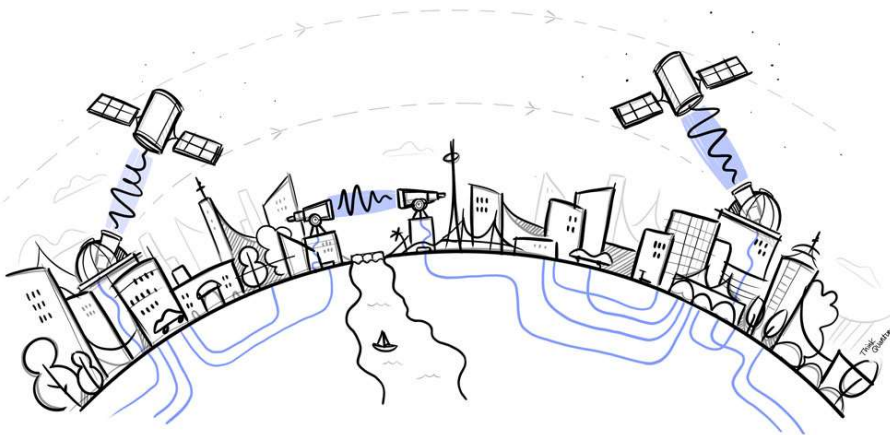

Protecting the Most Sensitive Medical Data

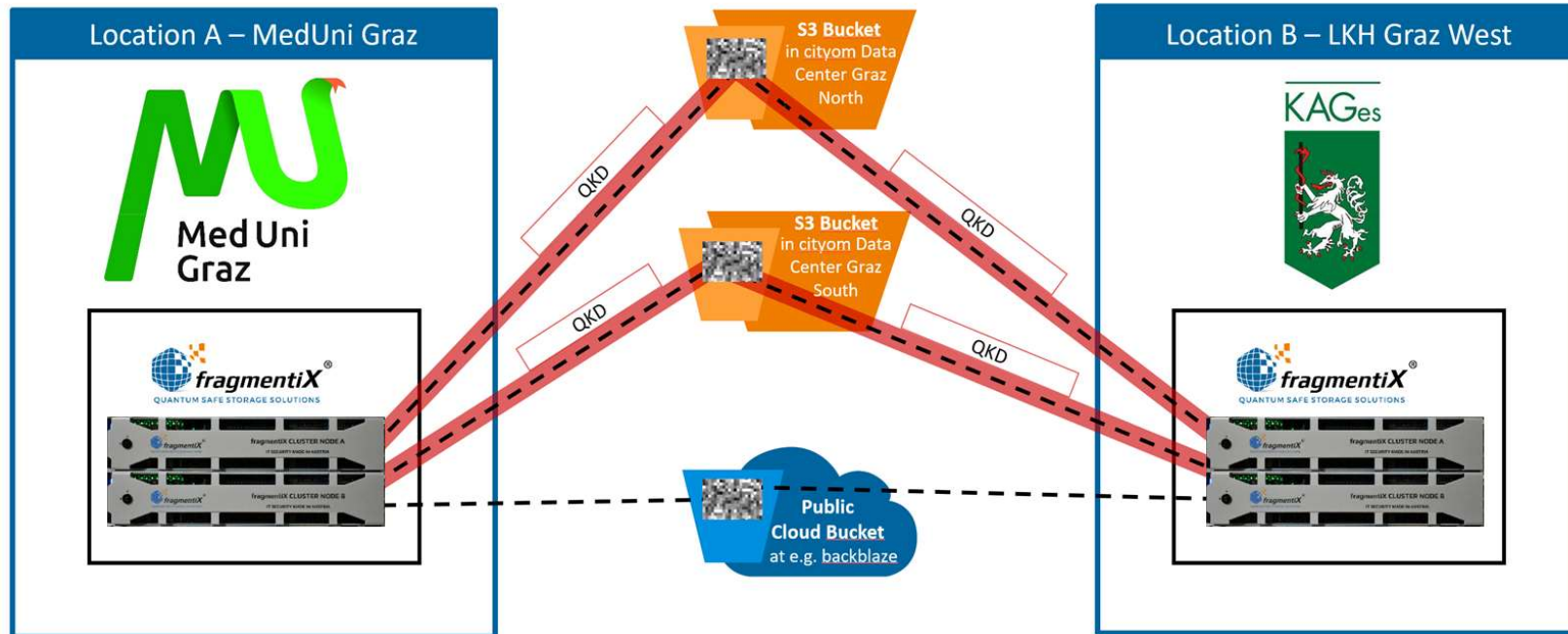

OPEN  QKD



This project has received funding from the European Union's Horizon 2020 research and innovation programme under grant agreement No 857156.

fragmentiX and QKD for Fortune 500 / Gov / Mil

Application A:
data protection at rest via fragmentiX,
data protection on transit via ADVA encryptors at ORG2 plus subsidiaries and storages A, B, C

Application B:
data protection at rest via fragmentiX,
data protection on transit partly via QKD

Application C:
data protection at rest via fragmentiX
https protected on transit, a single link QKD protected

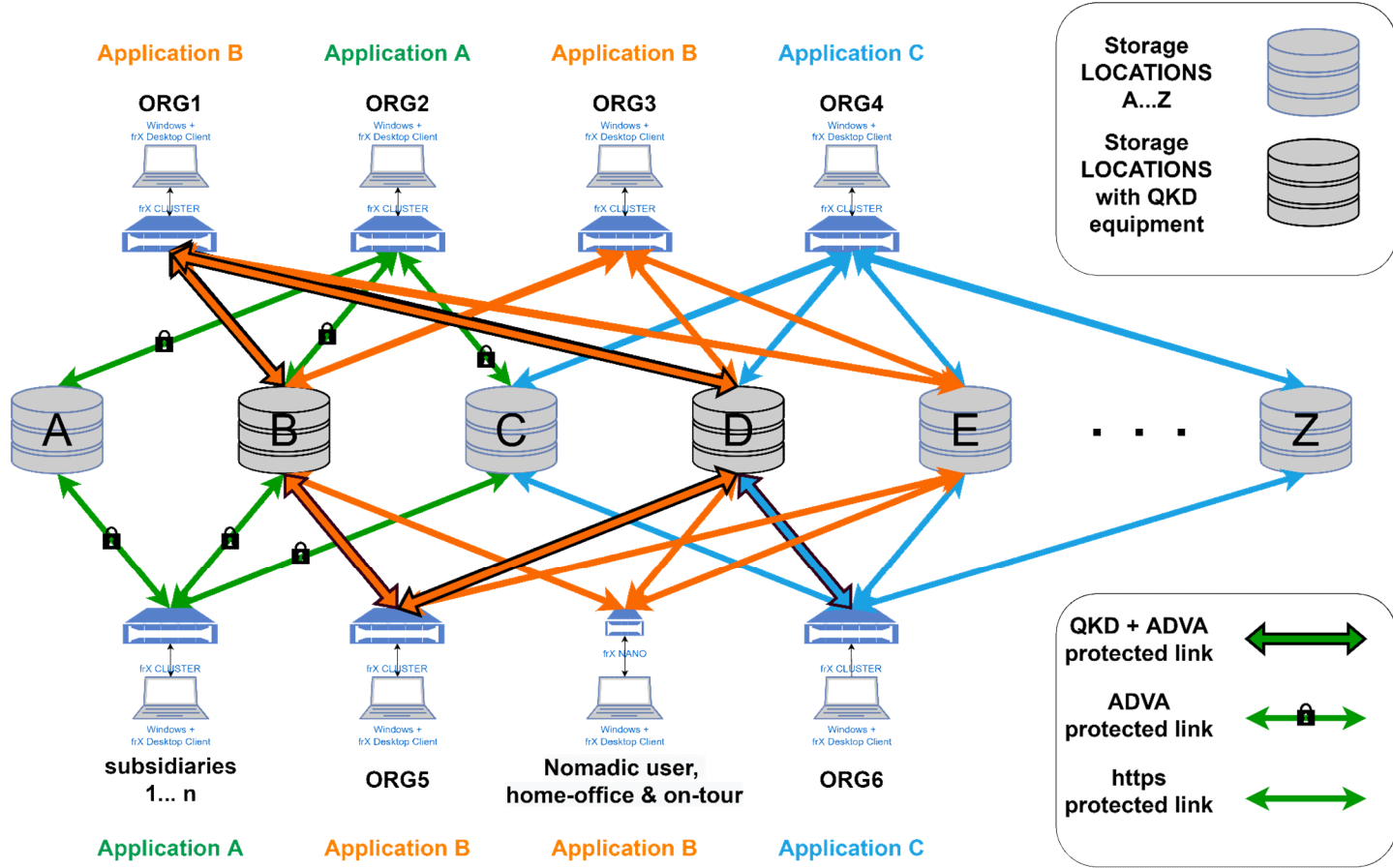

Regional SME Cyber-Security Support

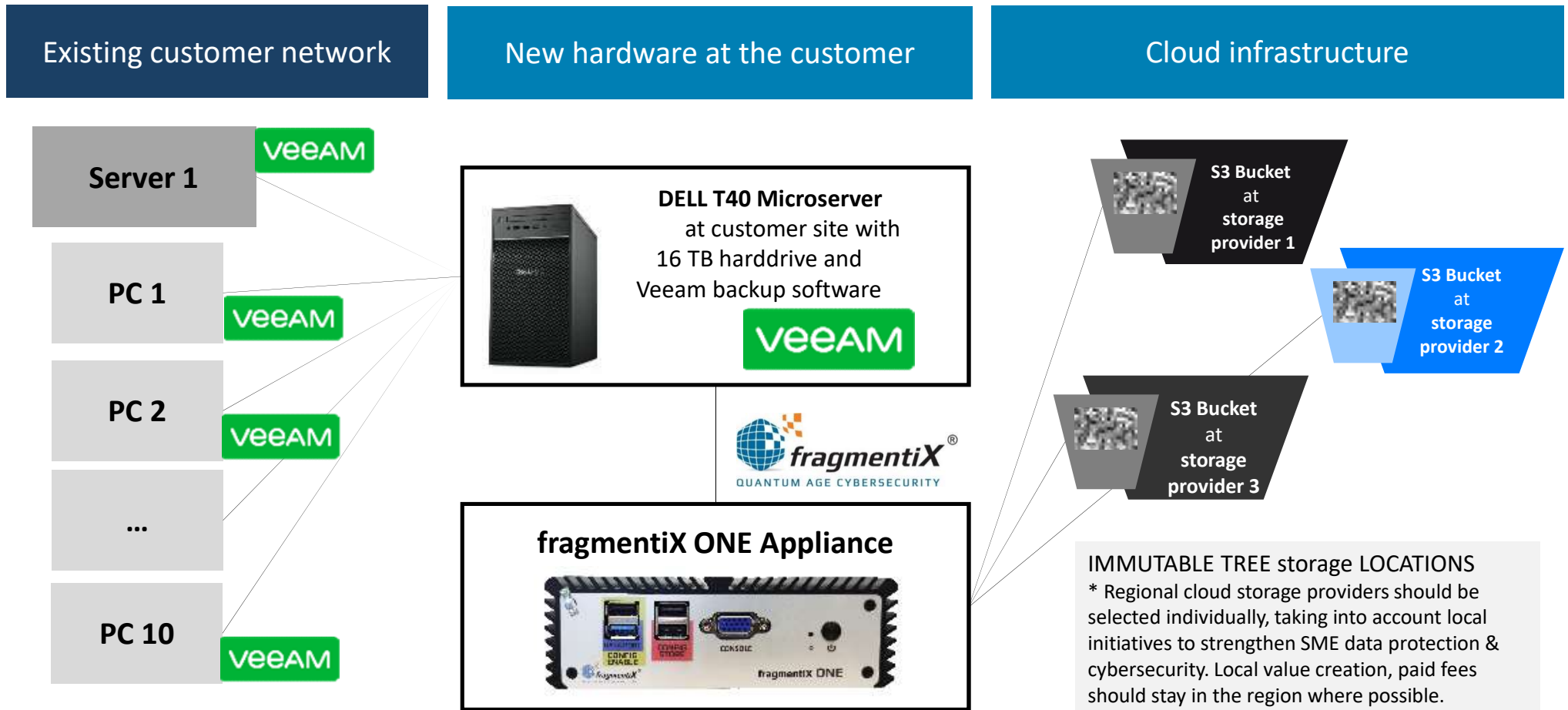

IMMUTABLE TREE storage LOCATIONS
* Regional cloud storage providers should be selected individually, taking into account local initiatives to strengthen SME data protection & cybersecurity. Local value creation, paid fees should stay in the region where possible.

Technology Cooperations (partial list)



fragmentiX is a global DELL OEM partner.

Dell manufactures the fragmentiX CLUSTER hardware base servers to our specifications within the EU – actually in Poland - and provides 5 years of worldwide mission critical support.

Every fragmentiX CLUSTER customer is entitled to on-site support within 4 hours around the globe, sensitive parts like SSDs under all circumstances stay at customer site.

All security-related components and the frXOS operating system are installed by fragmentiX, DELL has no access to any IP held by fragmentiX.

Technology Cooperations (partial list)



fragmentiX is a global Maxeler and groq technology and sales partner.

The combined expertise and technologies of Maxeler and groq form the basis for the highest performance in processing AI/ML and in particular also LLMs (Large Language Models such as Chat-GPT and Bard).

Since uncontrolled use of public LLMs is prohibited for many relevant domains, it became business-critical to enable the use of these techniques in the field - and to train and work with sensitive and restricted corporate or government data.

For the most critical parts of LLM training, the groq/Maxeler systems have proven to be up to several hundred times faster than other vendors' GPU systems.

Technology Cooperations (partial list)



The Austrian Institute of Technology (AIT) has been an innovation- and cooperation partner from the very beginning. Together, we bridge the gap between research and business in numerous ventures.



Since its foundation in 2011 in Germany, CLOUD & HEAT has become a leading provider of sustainable data center technology and customized liquid cooling solutions. CLOUD & HEAT became the relevant European provider of turnkey data center solutions for enterprises and critical infrastructure.



With Titanium, pioneers in the field of security through **data-in-use encryption**, based in Silicon Valley, USA, fragmentiX can provide users worldwide with optimal protection against ransomware and other data protection threats.

fragmentiX Essential Benefits



- fragmentiX delivers a **security level** that no single cloud storage provider alone can offer
 - **Information-Theoretic Security (ITS)** through Shamir Secret Sharing
 - Future quantum computers cannot hack or decrypt fragments: **quantum safe storage**
 - With fragmentiX there is **no more need to trust** any single provider or storage admin
- **High availability + strong resilience**
 - Multiple **low-cost** S3 storage providers – even with low service level – in combination with fragmentiX bring a higher security and resilience level compared to expensive high end storage providers
- **Prevent cloud provider lock-in** by using hybrid public / private cloud storage from the beginning
- World leading data security protection **against ransomware threats including extortion** with partners

Werner STRASSER, CEO & founder



- Werner Strasser (*1965) is an Austrian entrepreneur
- Training in precision engineering (today mechatronics), admin and repair of first Unix systems in Austria, graphic / departmental supercomputing / vector processing (today HPC), publishing and document management systems, search technologies for public authorities (binary pattern recognition, semantic networks, ontologies), video conferencing solutions for companies and public authorities including military applications.
- Since 1991 self-employed entrepreneur with different roles for authorities in Austria & EU, IT security related topics, protection of data against theft, sabotage etc.
- 2016 the AIT (Austrian Institute of Technology) introduced a Secret Sharing Implementation to Mr.Strasser which led to:
 - foundation of fragmentiX GmbH in July 2018 - since Sept. 2019 headquarters at IST Austria Technology Park in Klosterneuburg, Austria.
 - Foundation of fragmentiX Schweiz AG in the canton of Schwyz in Sept. 2020.
- Personal vision: Enabling everyone to protect their privacy, with an emphasis on digital sovereignty and dignity.
- Many years of expert work for, among others, the Ministries of the Interior, Justice and Defense in Austria.
- Unpaid voluntary teaching position for cyber recruits in "Digital Forensics" at the Academy of the Austrian Armed Forces.



+43 664 325 8896
ws@fragmentix.com

Headquarter & offices



Head office

fragmentiX Storage Solutions GmbH
xista science park, Ploecking 1
3400 Klosterneuburg
Austria / Europe

Contact us

» Head Office
+43 2243 24203
» sales@fragmentix.com
» www.fragmentix.com

Swiss office

fragmentiX Schweiz AG
Calendariaweg 2
6405 Immensee
Switzerland



Annex - fragmentiX Products



	ONE®	THREE®	FOUR®	CLUSTER®	NANO®
Application environments	Personal & SME Office 1-5 users	Office up to 20 users	Large groups and Authorities up to 40 users	Datacenters & enterprises	Working from home or while traveling in conjunction with fragmentiX CLUSTER®
Max.# storage LOCATIONS	8	16	26	26	3
Storage protocols / Storage media supported	AWS S3 compatible, MS Azure BLOB, NFS, USB	AWS S3 compatible, MS Azure BLOB, NFS, USB	AWS S3 compatible, MS Azure BLOB, NFS, USB	AWS S3 compatible, MS Azure BLOB, NFS	AWS S3 compatible, MS Azure BLOB, NFS
LAN interfaces	1 x 1 Gbit/s	1 x 1 Gbit/s	1 x 1 Gbit/s	1 x 10 Gbit/s SFP+ (potentially up to 8 with future upgrades)	2 x 1 Gbit/s
WAN interfaces	2 x 1 Gbit/s	4 x 1 Gbit/s	8 x 1 Gbit/s	8 x 10 Gbit/s SFP+	2 x 1 Gbit/s
CONFIG NET interface	1 x 1 Gbit/s	1 x 1 Gbit/s	1 x 1 Gbit/s	1 x 1 Gbit/s	-
# fragmentiX desktop client licenses included	5	10	20	50	1
frXOS firmware/OS updates included	1 year	1 year	1 year	1 year	1 year
HW mission critical support	-	-	-	5 years included	-
Size	154 x 128 x 49 mm	227 x 261 x 88 mm	227 x 261 x 88 mm	19", 2U	154 x 128 x 49 mm
Weight	0,7 kg	4,7 kg	4,7 kg	ca. 23 kg	0.7 kg
AC input	100-230V AC	100-230V AC	100-230V AC	100-230 V AC, 50/60 Hz	100-230 V AC
Power supply	36 W	120 W	120 W	2 x 495 W redundant	36 W